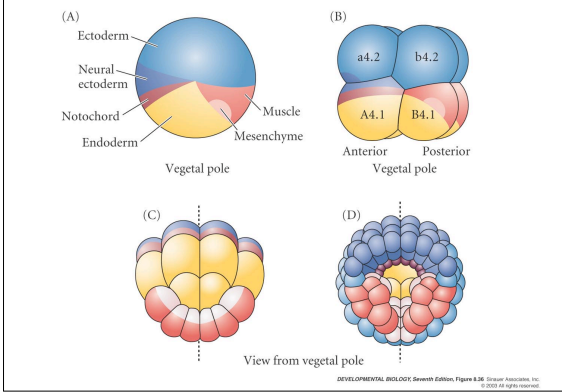

**Figure 8.36 Bilateral Symmetry in the Egg of the Tunicate *Styela partita***



---

---

---

---

---

---

---

---

**Fig. 8.37 Cytoplasmic Rearrangement in the Fertilized Egg of *Styela partita***

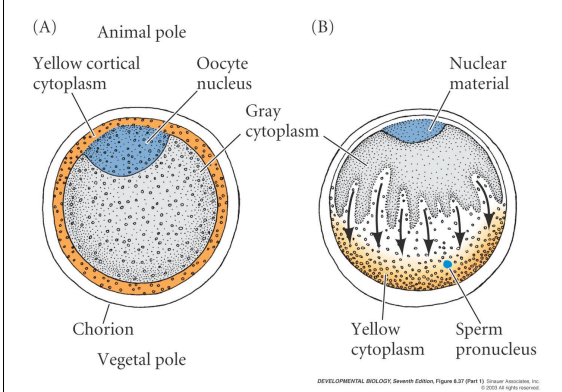

---

---

---

---

---

---

---

---

**Fig. 8.37 Cytoplasmic Rearrangement in the Fertilized Egg of *Styela partita***

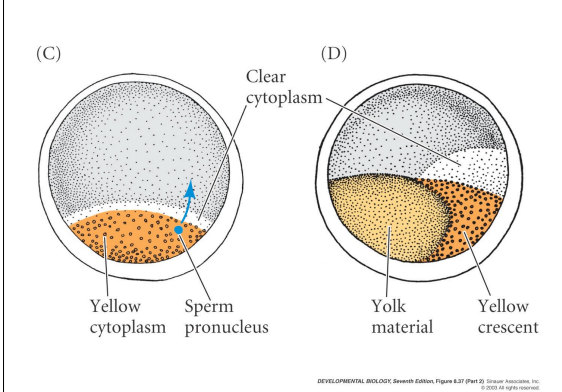

---

---

---

---

---

---

---

---

**Figure 8.38(1) Cytoplasmic Segregation in the Egg of *Styela partita*.**

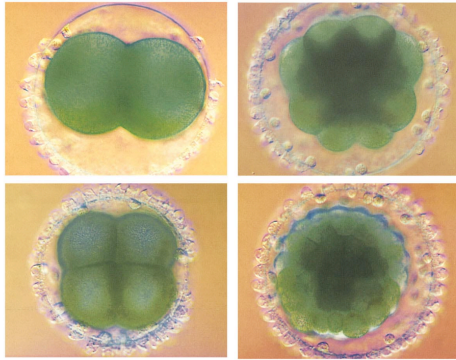

DEVELOPMENTAL BIOLOGY, Seventh Edition, Figure 8.38 © 2005 Sinauer Associates, Inc. All rights reserved.

---

---

---

---

---

---

---

---

**Figure 3.8 Autonomous Specification in the Early Tunicate Embryo**

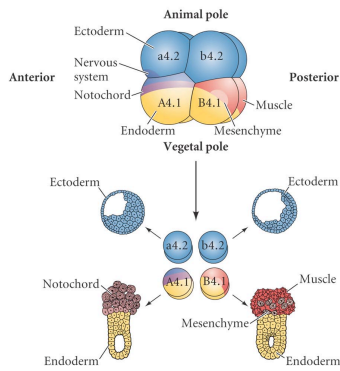

DEVELOPMENTAL BIOLOGY, Seventh Edition, Figure 3.8 © 2005 Sinauer Associates, Inc. All rights reserved.

---

---

---

---

---

---

---

---

**Figure 3.9 Acetylcholinesterase in Progeny of Muscle Lineage Blastomeres**

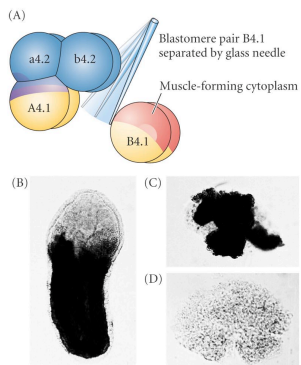

DEVELOPMENTAL BIOLOGY, Seventh Edition, Figure 3.9 © 2005 Sinauer Associates, Inc. All rights reserved.

---

---

---

---

---

---

---

---

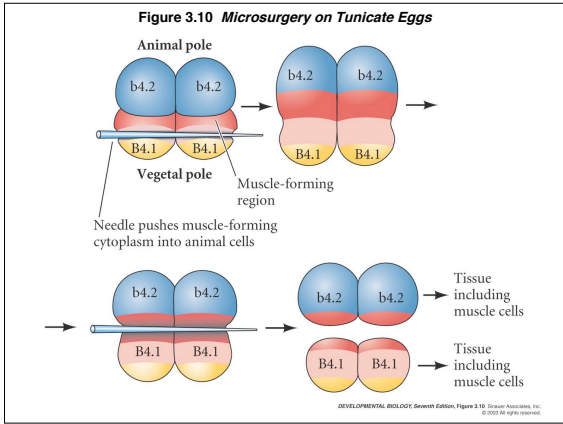

---

---

---

---

---

---

---

---

---

---

---

---

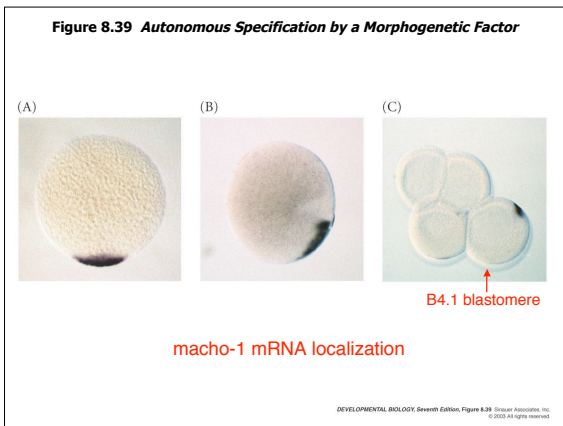

---

---

---

---

---

---

---

---

---

---

---

---

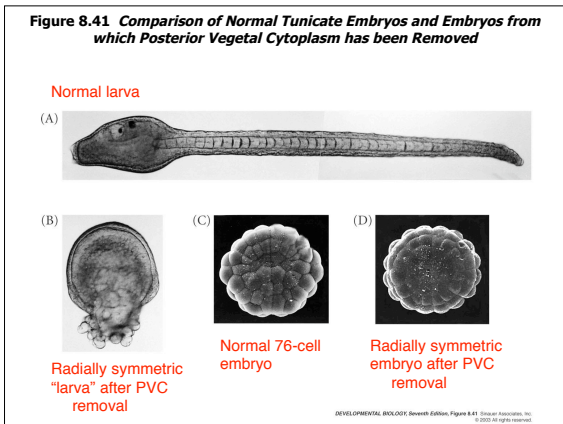

---

---

---

---

---

---

---

---

---

---

---

---

**Figure 8.40 Antibody Staining of  $\beta$ -catenin Protein Shows Its Involvement with Endoderm Formation**

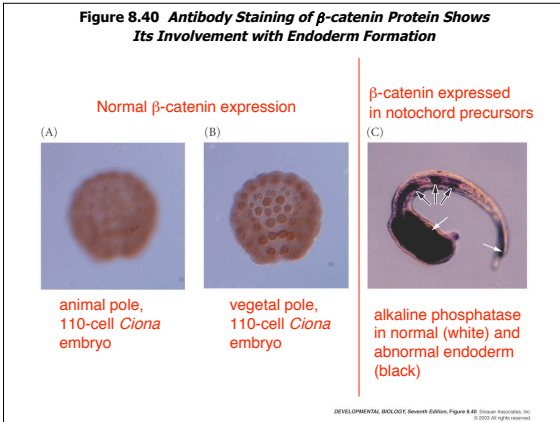

---

---

---

---

---

---

---

---

**Figure 8.43(2) *Caenorhabditis elegans***

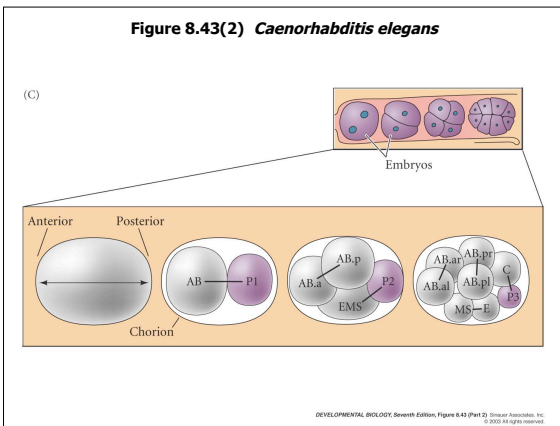

---

---

---

---

---

---

---

---

***Caenorhabditis elegans* embryonic development**

Autonomous specification:

P granule segregation

Endomesoderm specification  
- *skn-1* gene function

Conditional specification:

Endomesoderm specification  
- Wnt signaling

---

---

---

---

---

---

---

---



**Figure 8.44(1) Segregation of the P-granules into the Germ Line Lineage of the C. elegans Embryo**

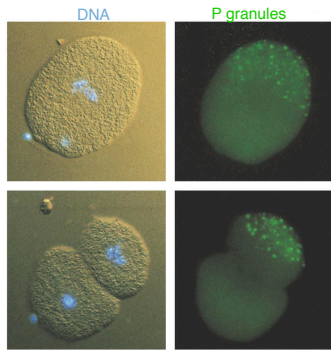

DEVELOPMENTAL BIOLOGY, Seventh Edition, Figure 8.44 (Part 1) © 2005 Sinauer Associates, Inc. All rights reserved.

---

---

---

---

---

---

---

---

**Figure 8.44(2) Segregation of the P-granules into the Germ Line Lineage of the C. elegans Embryo**

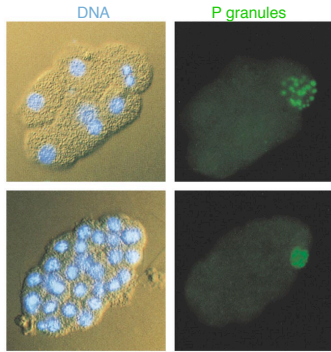

DEVELOPMENTAL BIOLOGY, Seventh Edition, Figure 8.44 (Part 2) © 2005 Sinauer Associates, Inc. All rights reserved.

---

---

---

---

---

---

---

---

**Segregation of the P-granules into the Germ Line Lineage**

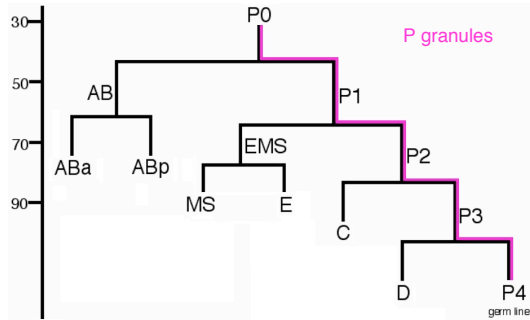

---

---

---

---

---

---

---

---

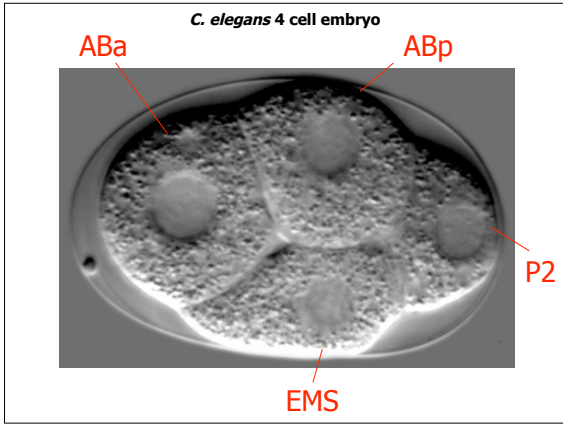

---

---

---

---

---

---

---

---

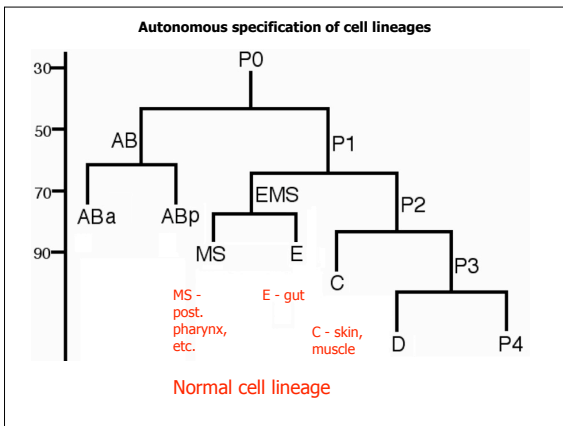

---

---

---

---

---

---

---

---

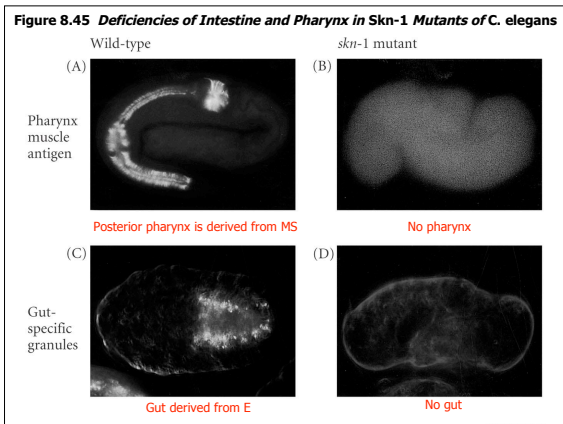

---

---

---

---

---

---

---

---

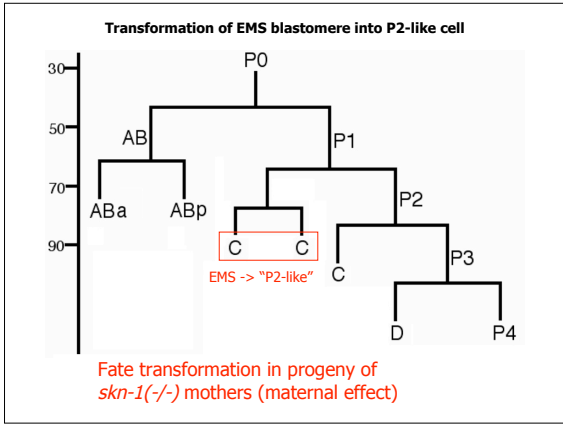

---

---

---

---

---

---

---

---

---

---

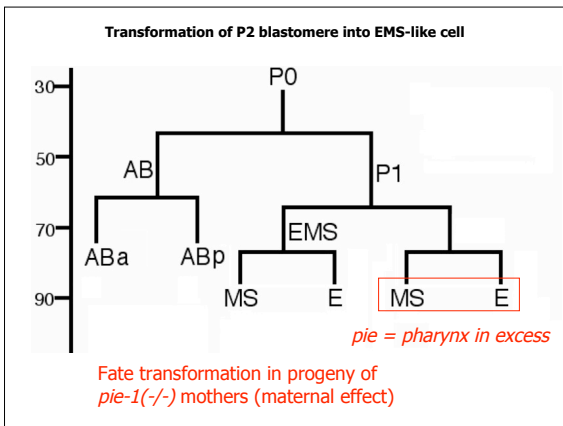

---

---

---

---

---

---

---

---

---

---

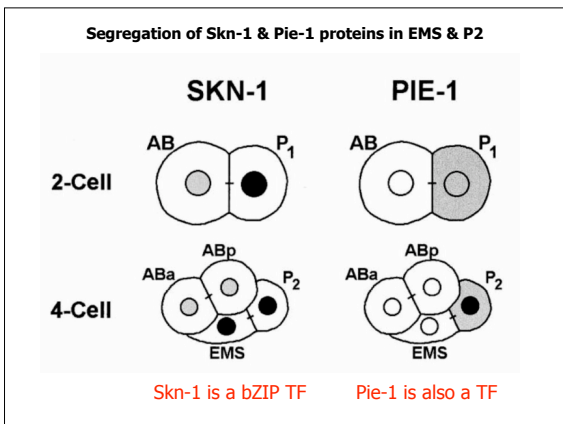

---

---

---

---

---

---

---

---

---

---

Segregation of Pie-1 protein into P cell germ line precursors

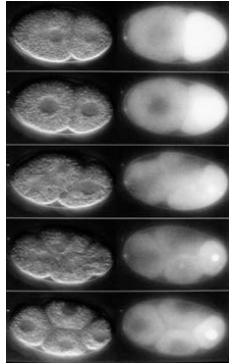

---

---

---

---

---

---

---

---

Segregation of Pie-1 protein into P cell germ line precursors

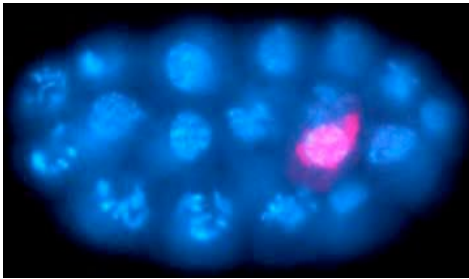

Blue: DAPI (nuclei) Red: Pie-1 protein  
Pie-1 is a component of P granules

---

---

---

---

---

---

---

---

Transformation of blastomeres in *mex-1* mutants

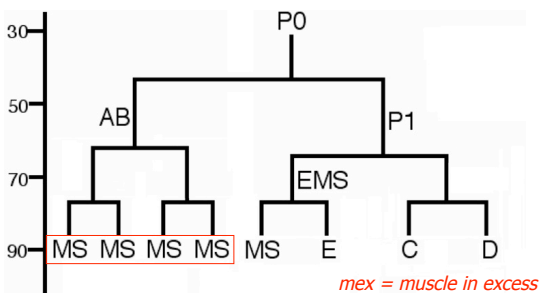

Fate transformation in progeny of *mex-1(-/-)* mothers (maternal effect)

---

---

---

---

---

---

---

---

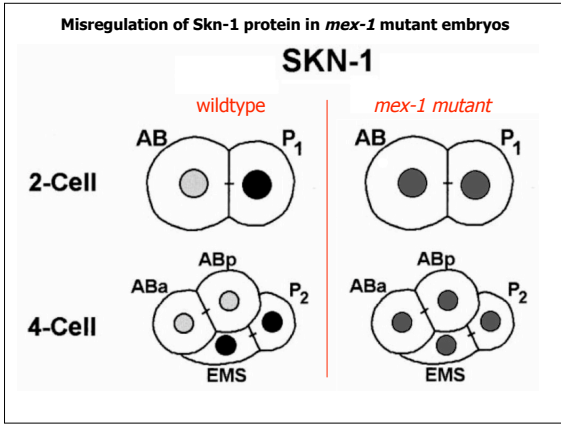

---

---

---

---

---

---

---

---

***Caenorhabditis elegans* embryonic development**

Endomesoderm specification  
also depends on cell-cell signaling

P2 signals EMS to promote endoderm  
formation in one of its progeny (E)

---

---

---

---

---

---

---

---

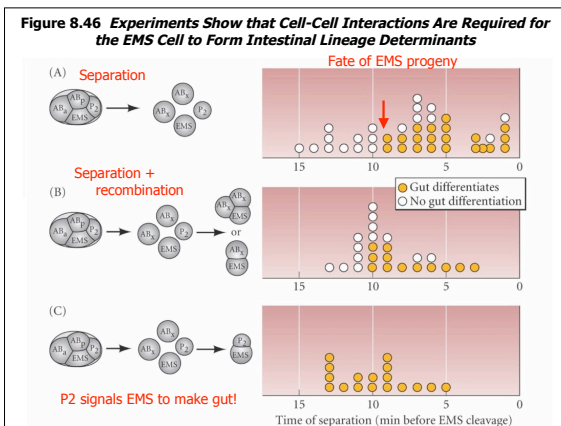

---

---

---

---

---

---

---

---

**Figure 8.47 Cell-Cell Signaling in the 4-Cell Embryo of *C. elegans***

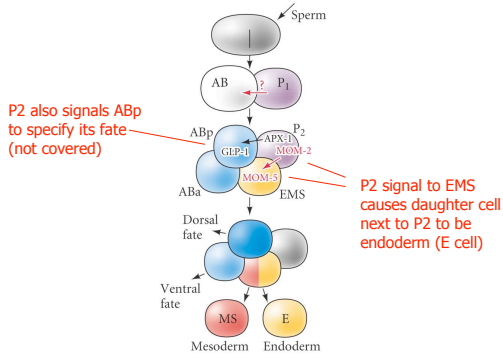

---

---

---

---

---

---

---

---

***C. elegans* Wnt signaling pathway in blastomere specification**

Maternal effect mutants affecting P2 → EMS signal:

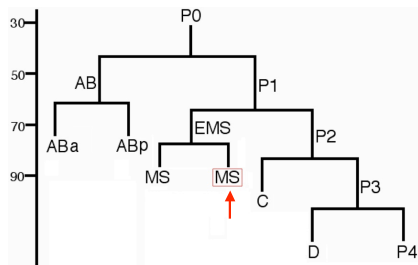

**Mom - "more of MS" (E transformed to MS)**

---

---

---

---

---

---

---

---

***C. elegans* Wnt signaling pathway in blastomere specification**

Maternal effect mutants affecting P2 → EMS signal:

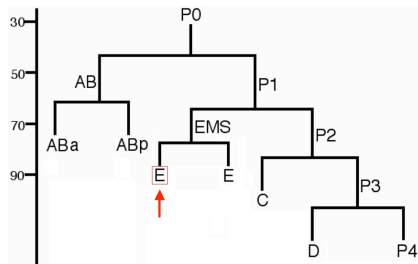

**Pop - "posterior pharynx defect" - opposite phenotype to Mom (MS transformed to E)**

---

---

---

---

---

---

---

---

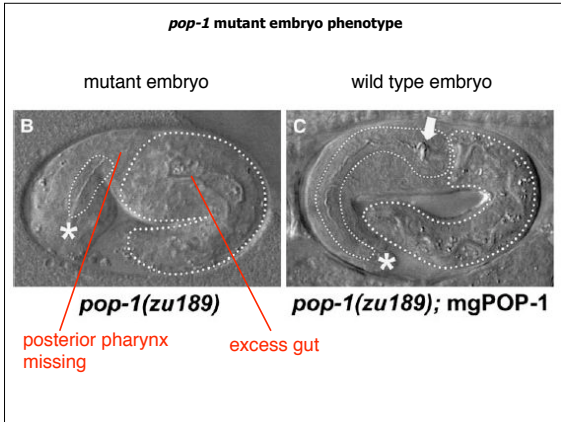

---

---

---

---

---

---

---

---

---

---

**C. elegans Wnt signaling pathway in blastomere specification**

P2 to EMS signal uses a Wnt signaling pathway

Mom-2	Wnt-like (secreted signal from P2)
Mom-5	Frizzled (receptor)
Gsk-3	GSK3 (kinase)
Wrm-1	$\beta$ -catenin (transcription factor)
Pop-1	TCF (transcription factor)

No apparent Dishevelled (Dsh) homolog

---

---

---

---

---

---

---

---

---

---

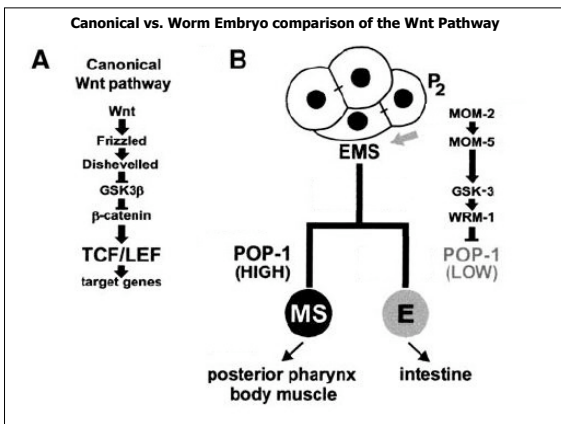

---

---

---

---

---

---

---

---

---

---

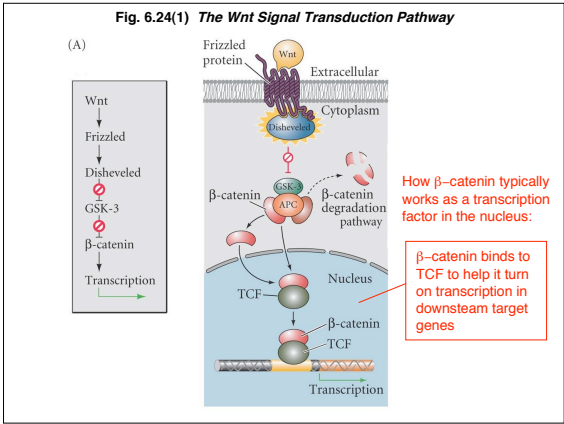

---

---

---

---

---

---

---

---

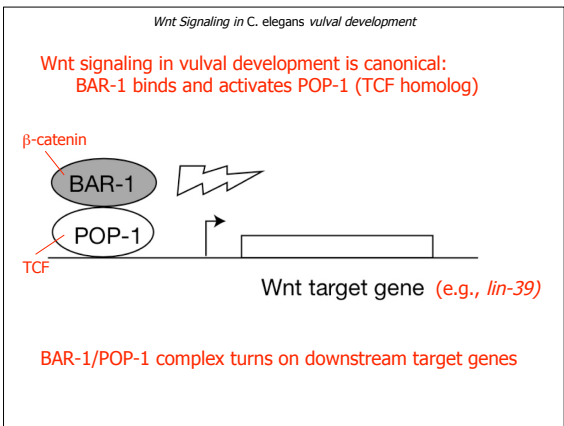

---

---

---

---

---

---

---

---

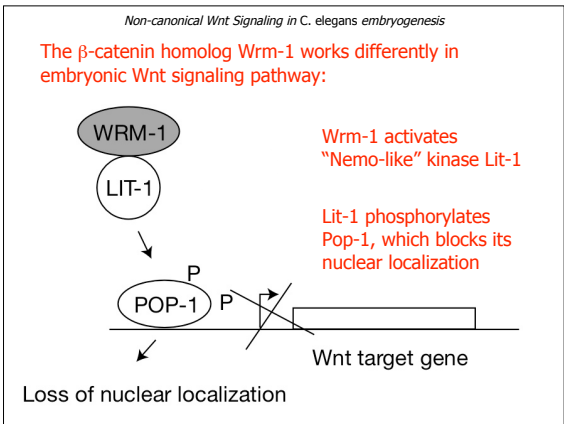

---

---

---

---

---

---

---

---

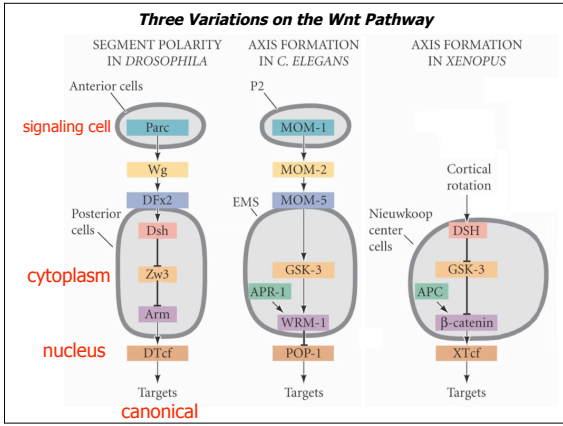

---



---



---



---



---



---