

ADS Tutorial Stability and Gain Circles EEE 194RF

The first step in designing the amplifier with the S parameter method is to determine whether the amplifier is unconditionally stable or potentially unstable. This can be easily estimated using the K stability factor and delta. The amplifier will be unconditionally stable if:

$$K > 1 \text{ and } \text{mag}(\Delta) < 1.$$

These factors are easily calculated using Measurement Equations in the ADS schematic panel. K is pre-programmed in as stab_fact which can be selected from the S-parameter palette on the left. Delta can be programmed yourself using a blank MeasEqn. The maximum available gain (MAG) and maximum stable gain (MSG) can also be calculated using the max_gain function.

The screenshot shows the ADS Schematic Panel for a simulation titled "Simulation-S_Param" with a project name "sp_mot_MMBR941_2_19". The main window displays a circuit diagram of a BJT amplifier. The transistor is labeled "SP" and has a biasing condition of "Bias='Bjt: Vce=6V Ic=10mA'". The input is connected to a 50 Ohm source (Term1) and the output is connected to a 50 Ohm load (Term2). The simulation parameters are listed as follows:

- S PARAMETERS**
 - S_Param
 - SP1
 - Start=100 MHz
 - Stop=2 GHz
 - Step=10 MHz
- MaxGain** (MeasEqn)
 - maxg1
 - maxg=max_gain(S)
- StabFact** (MeasEqn)
 - k1
 - our_k=stab_fact(S)
- MeasEqn**
 - meas4
 - mag_delta=mag(S11*S22-S12*S21)

Arrows point from the "MaxGain" and "StabFact" measurement equations to their respective icons in the left-hand S-parameter palette.

When swept over a range of frequencies, it can be clearly seen where the device will be unconditionally stable (above 1.5 GHz for this example). Note that the user-defined equation capability of the display panel is used to also calculate and plot MSG and the intrinsic transducer gain (GTi) with both Γ_S and $\Gamma_L = 0$. In the regions where $K < 1$, the max_gain function plots MSG. When unconditionally stable, it plots MAG.

ADS tip: When you want to plot from your user-defined equations, you need to select the equations dataset in the plotting panel.

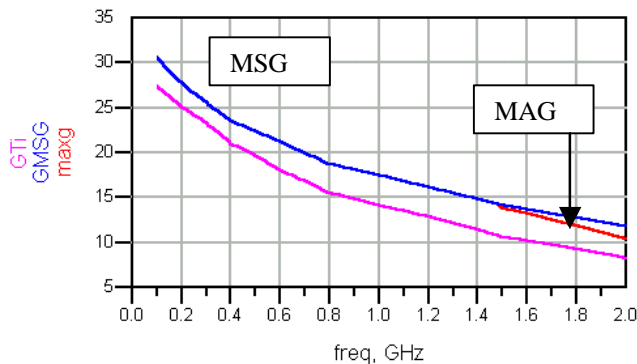
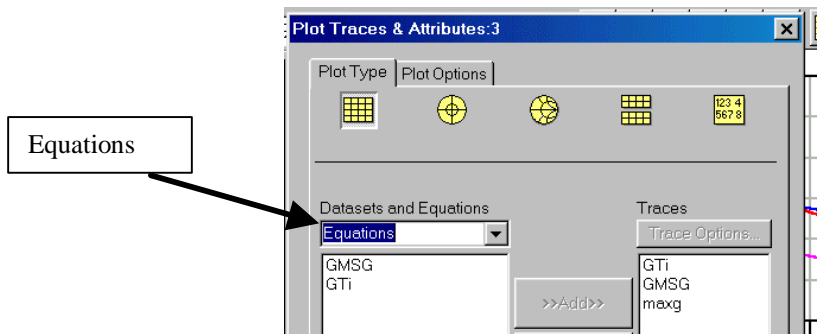

Eqn GMSG=10*log(mag(S21)/mag(S12))

Eqn GTi=20*log(mag(S21))

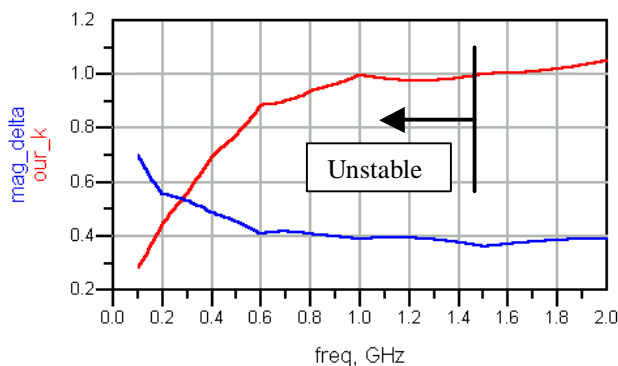

Next, you could check (as the book suggests) to see if the device is unilateral. (this is rarely the case). Evaluate the Unilateral Figure of Merit, U, at the design frequency using a Measurement Equation. Let's choose 500 MHz for our example.

```

MeasEqn Unilateral Figure of Merit
meas1
U=(mag(S12)*mag(S21)*mag(S11)*mag(S22))/((1-(mag(S11))**2)*(1-(mag(S22))**2))

MeasEqn
meas2
UFM_minus=10*log(1/((1+U)**2))

MeasEqn
meas3
UFM_plus=10*log(1/((1-U)**2))
  
```

Show the result in a table in the display panel.

freq	U	UFM_minus	UFM_plus
500.0MHz	0.137	-1.114	1.278

Here, we see that at 500 MHz, the device is clearly not unilateral. The unilateral approximation would have an error of over 1 dB.

Bilateral design. If the device is unconditionally stable at the design frequency, then the input and output can be conjugately matched as shown in Section 3.6 of Gonzalez. Γ_{MS} and Γ_{ML} can be determined uniquely. The input and output VSWR would = 1 in this case. This would be applicable for this device in the region where $K > 1$. The conjugate match reflection coefficients can be calculated on ADS using the Smgm1 and Smgm2 measurement equation icons in the S-parameter palette.

However, at 500 MHz, we find that $K = 0.75$. We must take into account stability as well as gain. It is wise to design the amplifier for less than the MSG to allow margin for stability. In this case, we need a systematic design method, because changes in Γ_S will affect Γ_{OUT} and changes in Γ_L will affect Γ_{IN} .

The operating power gain, G_P , provides a graphical design method suitable for bilateral amplifiers. Gain circles can be calculated that show contours of constant operating power gain. G_P is useful since it is independent of the source impedance; the gain circle represents the gain what would be obtained if a magic genie adjusted $\Gamma_S = \Gamma_{IN}^*$ for each value of Γ_L on the circle. Then, $G_P = G_T$, ie. the operating power gain equals the transducer gain. Let's illustrate.

Since we will need to evaluate the load plane for stability, so stability circles should also be calculated. This is done by using the LstbCir function. Source stability circles should also be calculated.

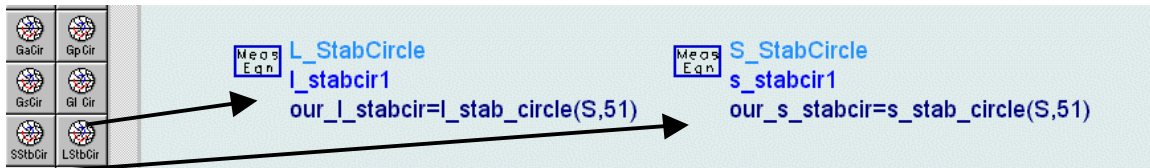

I have found it more convenient to calculate the operating power gain circles on the data display rather than on the schematic. On the data display, you can change the gain values without having to resimulate the amplifier. Use the Eqn function to write gain circle equations. The syntax is: `gp_circle(S, gain, # points on circle)` where S is the S-parameter matrix. In the example below, the gain circles at MSG, and 1 and 2 dB below MSG are plotted. A marker is placed on the -2 dB circle. Γ_L can be read off the display as magnitude = 0.057 with angle = 22 degrees. If the input is conjugately matched (and stable), then the gain should be $\text{maxg} - 2 = 20.4$ dB.

The load stability circle is also shown. The load impedance can be chosen away from this circle to maximize stability.

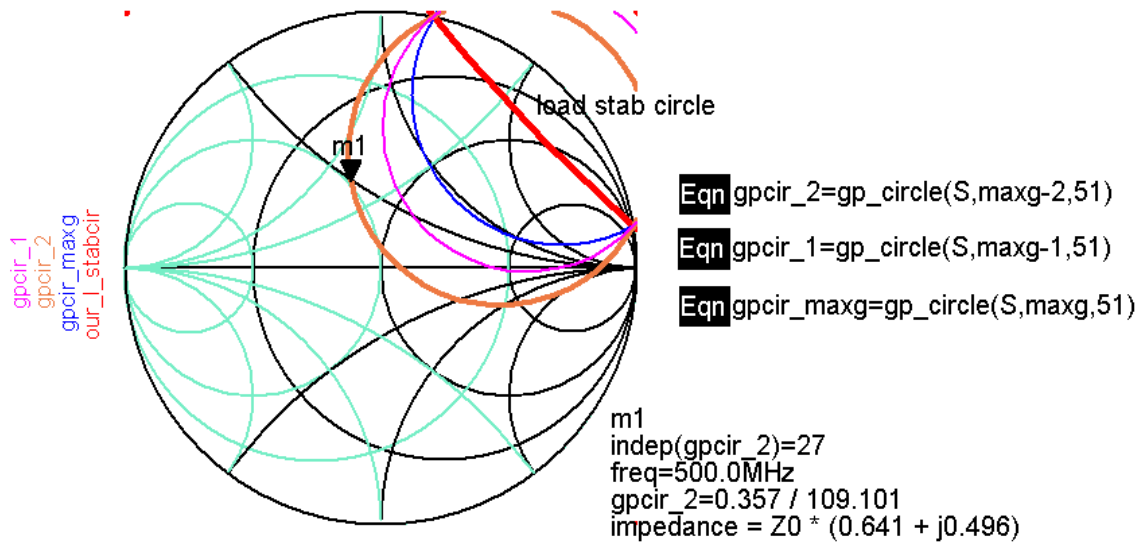

Next, calculate the input reflection coefficient for your choice of Γ_L and make sure it is stable. To do this, plot the source plane stability circle and compare with Γ_{IN} . You can use the marker (m2) to compare values of the source stability circle reflection coefficient with γ_{IN} . We can see that this choice will be stable at the design frequency.

$\text{Eqn } \gamma_{L} = m1[0]$ $\text{Eqn } \gamma_{S} = \text{conj}(\gamma_{IN})$
 $\text{Eqn } \gamma_{IN} = S_{11} + (S_{12} * S_{21} * \gamma_{L}) / (1 - S_{22} * \gamma_{L})$

γ_{IN}	γ_{S}	γ_{L}
0.486 / -91.799	0.486 / 91.799	0.357 / 109.101

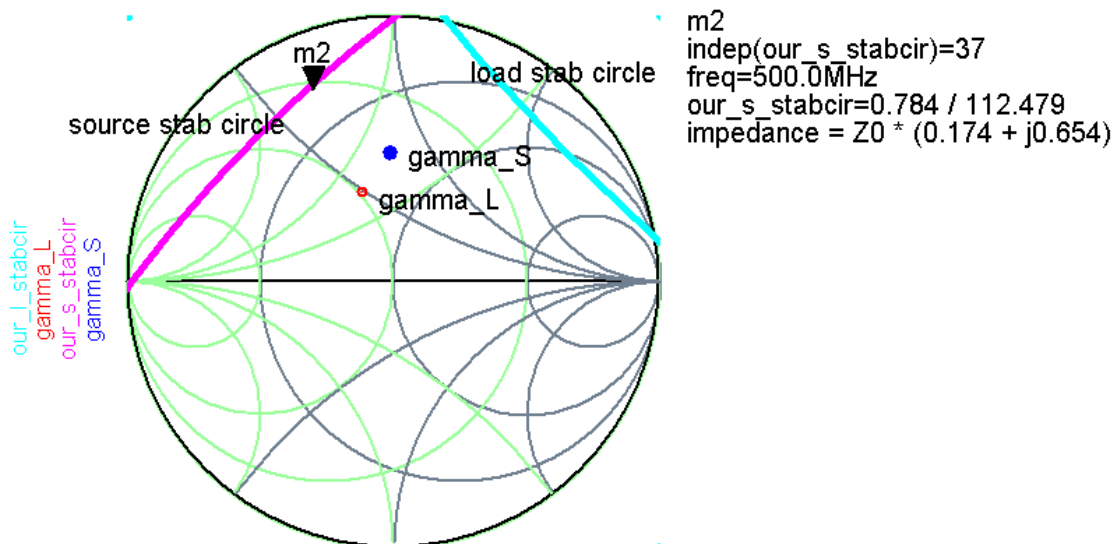

Biasing and matching network design. The next step in designing the amplifier will be the implementation of the input and output matching networks such that they provide reflection coefficients Γ_S and Γ_L as determined above. This can be done using the Smith chart. In general, there may be several solutions possible using lumped or distributed L networks. In selecting a design, you need to consider how you will bias the amplifier. You have 2 choices: bias with RF chokes and blocking capacitors or bias through the matching network elements.

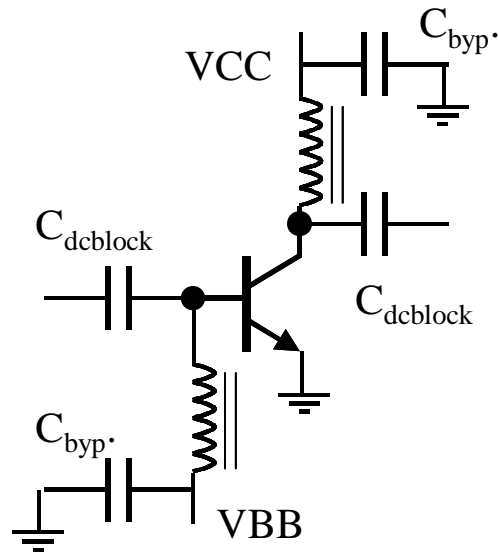

When possible, biasing through the matching network will often minimize the number of components and may prove to be easier to implement. Consider the load plane.

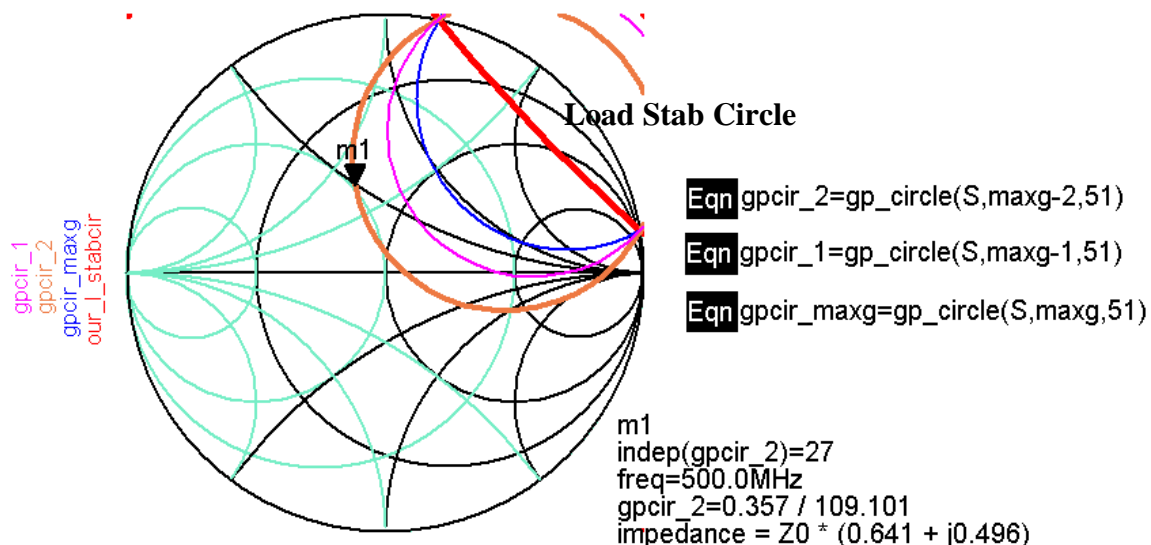

The marker is on the -2 dB operating power gain circle and represents our choice of Γ_L . Notice that we have many options for Γ_L as long as we keep a respectable distance from the load stability circle. As shown above, if we choose a Γ_L at the location of m1, we are on the unit constant conductance circle ($g=1$). Adding a shunt inductance across the 50

ohm load will place us at m1. The shunt inductance can be implemented with a shorted transmission line stub. This stub can also serve as our bias port if we are careful to provide appropriate bypass capacitance for the power supply.

gamma_IN	gamma_S	gamma_L
0.486 / -91.799	0.486 / 91.799	0.357 / 109.101

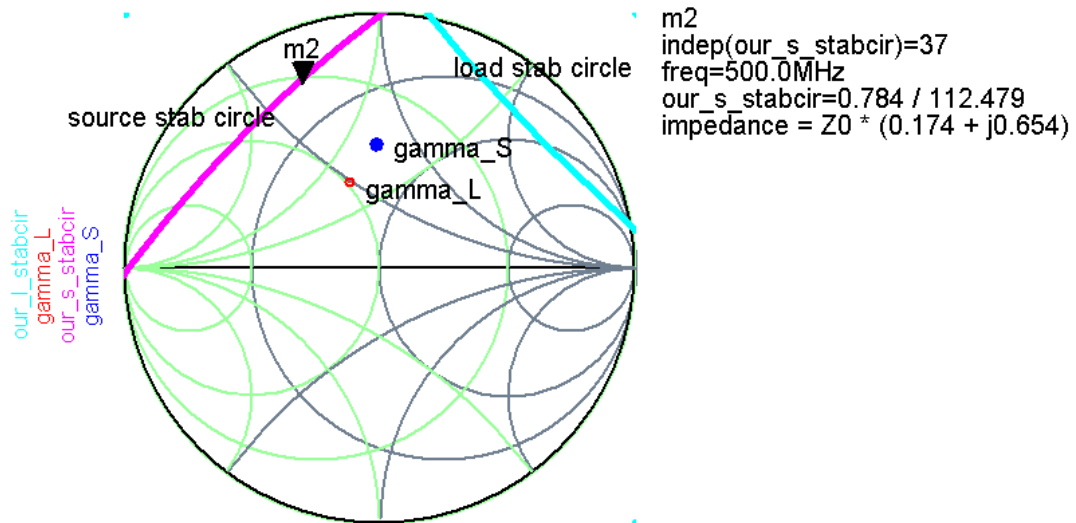

We can use the same idea for the source plane: add shunt inductance, moving up the $g=1$ circle. Then add a series 50 ohm transmission line until you reach Γ_S . The complete circuit looks like this:

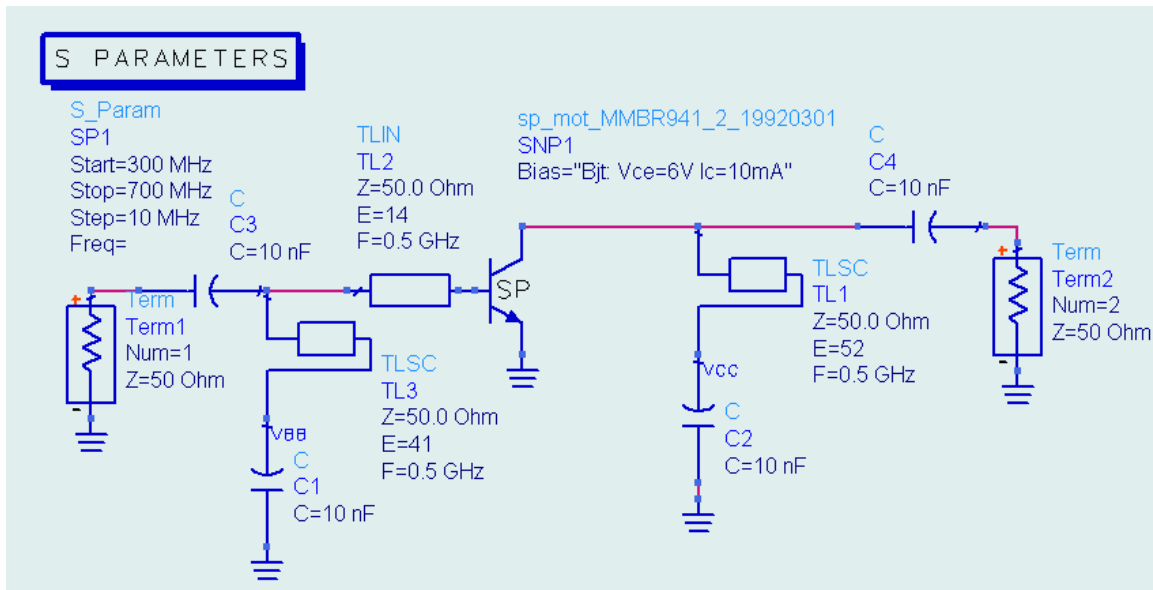

The capacitors are needed for bypassing and DC blocking. If we simulate this amplifier at the design frequency, it produces the expected gain of 20.3 dB. Although the K factor is less than 1, S11 and S22 both have magnitudes less than 1 which implies that the amplifier will be stable. We have a good input match as expected.

freq	our_k	GP	S(2,2)	S(1,1)
500.0MHz	0.779	20.343	0.659 / 32....	0.022 / 86....

$$\text{Eqn GP} = 20 * \log(\text{mag}(S_{21}))$$

Wideband Stability. We must also guarantee that the amplifier is stable not only at the design frequency but everywhere else as well. To do this, we will sweep the frequency over a wide range (100 MHz to 2 GHz) and look at S11 and S22. Here, we can see that S22 is greater than 1 at 300 MHz. We must modify the circuit to prevent this.

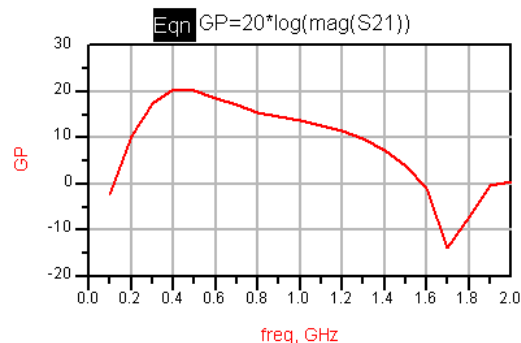
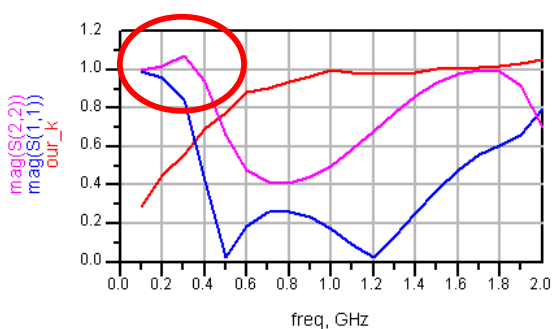

We could simulate the transistor again at 300 MHz and look at stability circles. Then, if you simulate the matching networks at this frequency to find Γ_S and Γ_L , it turns out that Γ_S is beyond the stability circle boundary. We could try a different Γ_L and test again. But, we may be able to solve the problem directly. Notice that the matching networks both have shunt lines that become short circuits at low frequencies. The device may become unstable as we approach Γ_L or $\Gamma_S = 1$. So, add some small series resistance to these shunt stubs to modify the low frequency behavior. Fortunately, this works in this case. Adding 5 ohms in series with each stub costs about 1 dB of gain, but keeps $\text{mag}(S_{22}) < 1$ at all frequencies.

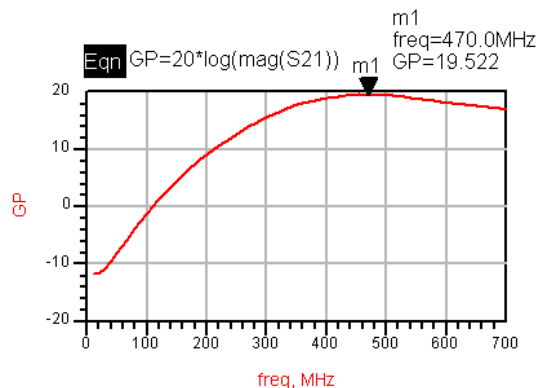
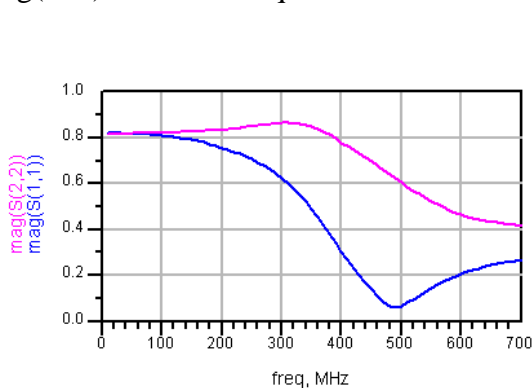

Other alternatives for stabilization would include adding the stabilizing resistor at the device using the stability circle technique at 300 MHz, or possibly choosing a different

Γ_L value to start with might produce a stable design. You can see that the wideband stabilization of an amplifier can involve some effort in design.

If RF chokes were used for biasing instead of the matching network approach, we would need to model the RFC as an equivalent RLC network and determine stability of the amplifier over a wide frequency range as well.

Our final design looks like this:

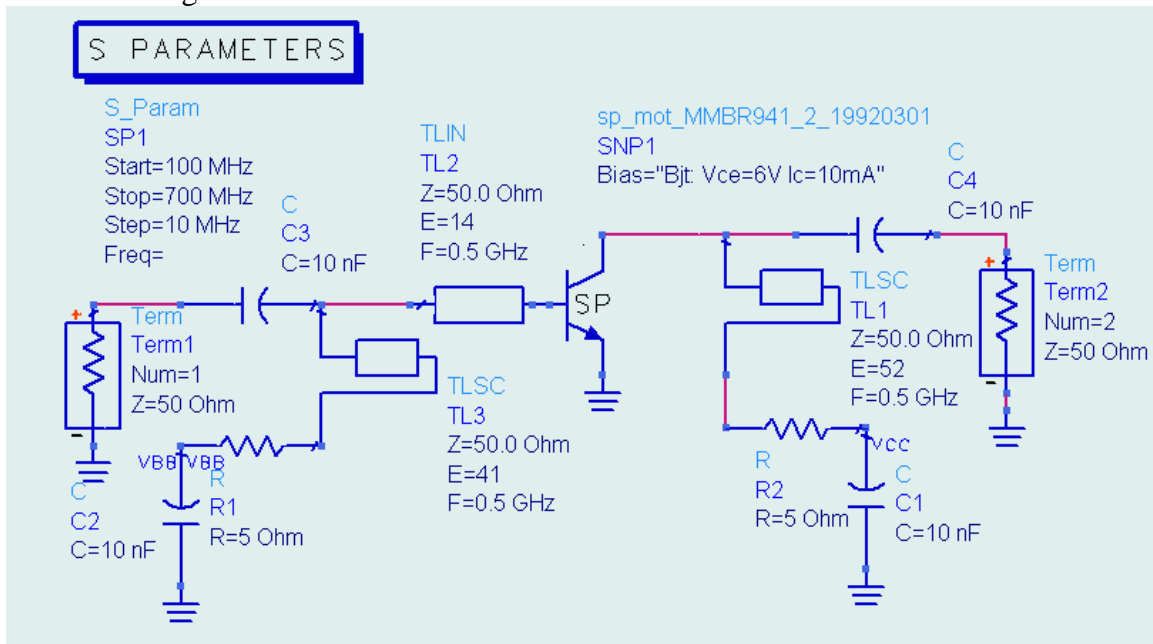

A suitable bias control circuit will now be needed to maintain the correct VCE and IC values for the amplifier. Note that constant VBE or constant IB designs are not acceptable because of the exponential temperature dependence of IC on VBE and because of the large temperature coefficient of β (0.7%/degree C).